

Code: 13A03101

B.Tech I Year (R13) Supplementary Examinations December/January 2015/2016

ENGINEERING DRAWING

(Common to CE and ME)

Time: 3 hours

Max. Marks: 70

(Answer all five units, 05 X 14 = 70 Marks)

UNIT – I

- 1 (a) Construct an ellipse when the distance of the focus from the directrix is equal to 50 mm and eccentricity is $\frac{2}{3}$.
- (b) A thin circular disc of 50 mm diameter is allowed to roll without slipping from upper edge of sloping plank which is inclined at 15° with the horizontal plane. Draw the curve traced by the point on the circumference of the disc.

OR

- 2 (a) Construct a hyperbola, when the distance of the focus from the directrix is 65 mm and eccentricity is $\frac{3}{2}$.
- (b) A thin triangular equilateral plate of 20 mm side is pinned at its centroid O. An inelastic string circumscribes complete perimeter of the plate. One end of the string is attached to one of the apex of the plate. Draw the curve traced out by other end of string keeping it tight, when string is unwound.

UNIT – II

- 3 (a) The length of top view of a line parallel to the V.P and inclined at 45° to the H.P is 50 mm. One end of the line is 12 mm above the H.P and 25 mm in front of the V.P. Draw the projections of the line and determine its true length.
- (b) Draw the projections of a circle of 50 mm diameter, having its plane vertical and inclined at 30° to the V.P. Its centre is 30 mm above the H.P and 20 mm in front of the V.P.

OR

- 4 (a) A line AB, 65 mm long, has its end A 20 mm above the H.P and 25 mm in front of the V.P. The end B is 40 mm above the H.P and 65 mm in front of V.P. Draw the projections of AB and show its inclinations with the H.P and V.P.
- (b) A circular plate of negligible thickness and 50 mm diameter appears as an ellipse in the front view, having its major axis 50 mm long and minor axis 30 mm long. Draw its top view when the major axis of the ellipse is horizontal.

UNIT – III

- 5 (a) Draw the projections of a pentagonal prism, base 25 mm side and axis 50 mm long, resting on one of its rectangular faces on the H.P, with the axis inclined at 45° to the V.P.
- (b) A pentagonal pyramid of base 30 mm and axis 60 mm long resting with one of its edges on H.P, perpendicular to V.P and axis parallel to V.P. It is cut by a plane perpendicular V.P and inclined at 60° to H.P. The cutting plane meets the axis at a distance 30 mm from top to the base. Draw the section plan and true shape of the section.

OR

- 6 (a) Draw the projections of a cone, base 75 mm diameter and axis 100 mm long, lying on the H.P on one of its generators with the axis parallel to the V.P.
- (b) A cylinder of base diameter 50 mm and height 60 mm rests on its base on H.P. It is cut by a plane perpendicular V.P and inclined at 45° to H.P. The cutting plane meets the axis at a distance 15 mm from top to the base. Draw the section plan and true shape of the section.

Contd. in page 2

UNIT - IV

7 Draw the isometric view of the casting shown in two views in the following figure. (All dimensions are in mm)

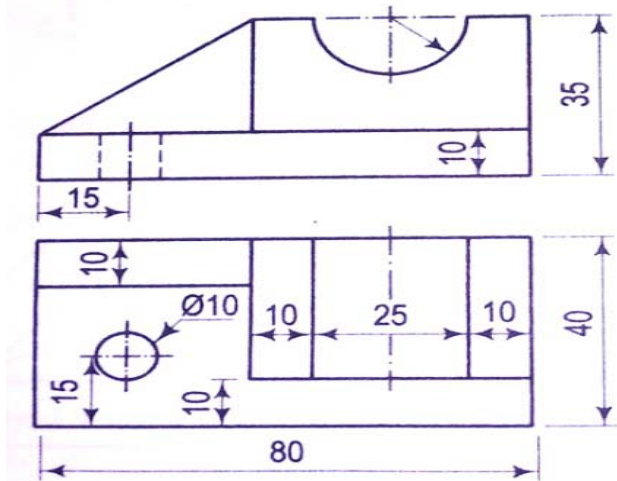

OR

8 Draw the front view, top view and left side view of the block shown in figure below. (All dimensions are in mm)

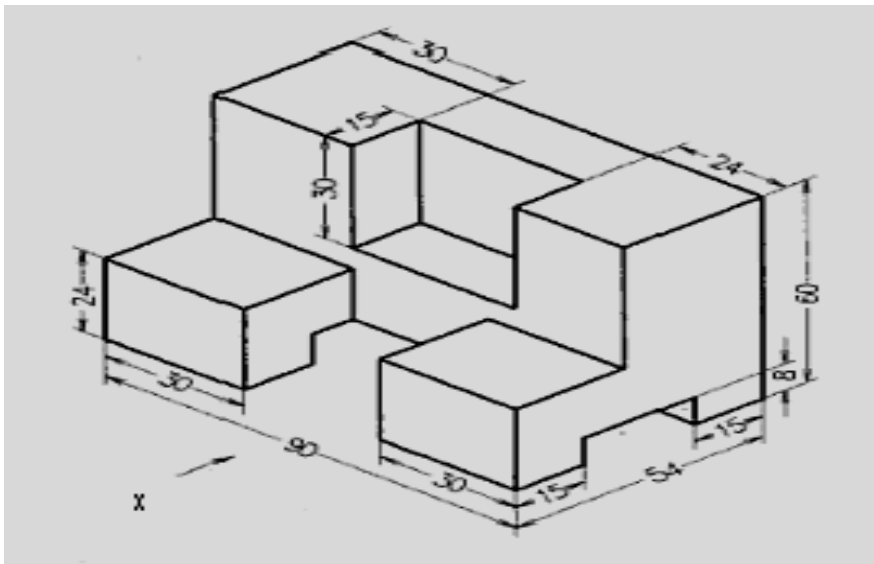

UNIT - V

9 A vertical square prism, base 50 mm side and height 120 mm, is completely penetrated by a horizontal square prism, base 35 mm side and height 135 mm, so that their axes are 6 mm apart. The axis of horizontal prism is parallel to the V.P, while the faces of both prisms are equally inclined to the V.P. Draw the projections of the prisms showing lines of intersection.

OR

10 A rectangular block 30 mm x 20 mm x 15 mm, is lying on the ground plane on one of its largest faces. A vertical edge is in the picture plane and the longer face containing that edge makes an angle of 30° with the picture plane. The station point is 50 mm in front of the picture plane, 30 mm above the ground plane and lies in a central plane which passes through the centre of the block. Draw the perspective view of the block.
