

ENGINEERING DRAWING

(Common to CE, ME, AE, MCTE & Ch.E)

Time: 3 hours

Max. Marks: 70

(Answer all five units, 05 X 14 = 70 Marks)

UNIT-I

- 1 (a) The vertex of a hyperbola is 60 mm from its focus. Draw the curve, if the eccentricity is $3/2$. Draw a normal and a tangent at a point on the curve, 75 mm from the directrix.
- (b) Draw a hypo cycloid of a circle of 50 mm diameter, which rolls inside another circle of 180 mm diameter for one revolution counter clockwise.

OR

- 2 (a) Draw an epicycloid if a circle of 40 mm diameter rolls outside another circle of 120 mm diameter for one revolution.
- (b) Draw the involute of a regular hexagon of side 20 mm. Draw a tangent and normal to the curve at a distance of 100 mm from the center of the hexagon.

UNIT-II

- 3 (a) Draw the projections of a line CD 30 mm long, parallel to HP and inclined to VP. The end C is 10 mm in front of VP and D is 20 mm in front of VP. The line is 15 mm above HP. Also find the traces.
- (b) Draw the projections of regular hexagon of 25 mm side having one of its edge in H.P and inclined at 60° to V.P and its surface making an angle of 60° to H.P.

OR

- 4 (a) A line measuring 80 mm long has one of its ends 60 mm above HP and 20 mm in front of VP. The other end is 15 mm above HP and in front of VP. The front view of the line is 60 mm long. Draw the top view.
- (b) Draw the projections of regular pentagon of 40 mm side, having its surface inclined at 30° to VP and the side on which it rests on VP, makes an angle of 60° with HP.

UNIT-III

- 5 (a) Draw the projections of a pentagonal pyramid, base 30 mm edge and axis 50 mm long, having its base on the H.P and an edge of the base parallel to the V.P.
- (b) A pentagonal pyramid of base side 40 mm and axis length 75 mm is resting on HP on its base with one of its base side parallel to VP. It is cut by a plane inclined at 35° to HP and perpendicular to VP and bisecting the axis. Draw its front view, sectional top view and true shape of section.

OR

- 6 (a) Draw the projections of cone of base 50 mm diameter, axis 60 mm long, resting on ground on its base.
- (b) A pentagonal prism is resting on one of the corners of its base on the H.P. The longer edge containing that corners is inclined at 45° to the H.P. The axis of the prism makes an angle of 30° to the V.P. Draw its projections of the solid.

Contd. in page 2

Code: 13A03101

UNIT-IV

7 Draw the elevation, plan and right side view of the part shown in the picture below. (dimensions in mm)

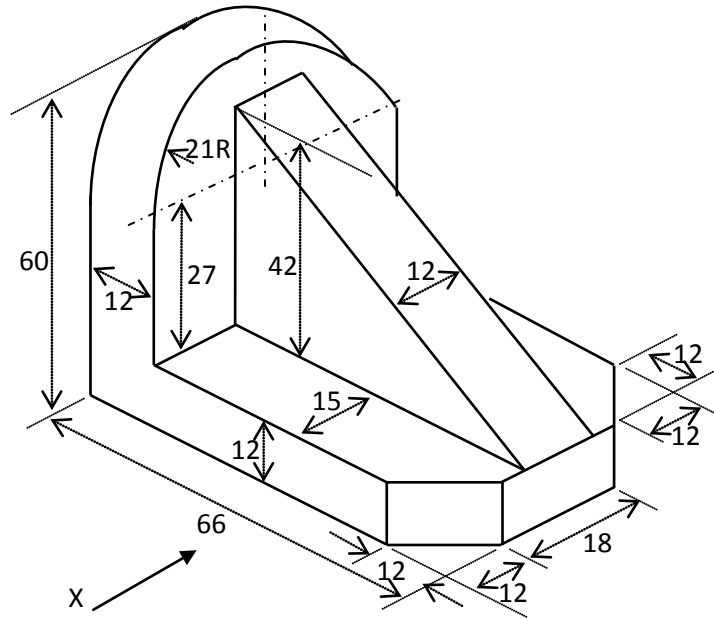

OR

8 Two views of a casting are shown below. Draw the isometric view of the casting (dimensions are in mm).

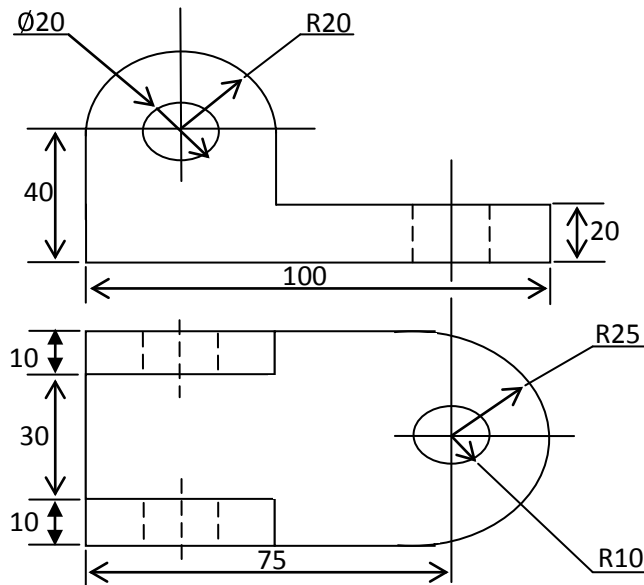

UNIT-V

9 A square prism, having base with a 50 mm side and a 90 mm long axis, rests on its base on the ground with a face inclined at 30° to the V.P. It is penetrated by a horizontal cylinder with a 40 mm diameter. Their axes bisect each other at right angles. Draw three views of the combination and show the curves of intersection.

OR

10 A square pyramid of side of base 30 mm and axis 40 mm long rests with its base on the ground plane such that one of its base sides is parallel to the picture plane and 10 mm in front of it. The station point is 50 mm in front of the picture plane, 25 mm to the left of the axis of the pyramid and 55 mm above the ground. Draw the perspective projection.