

B.Tech II Year II Semester (R13) Regular & Supplementary Examinations May/June 2016

PULSE & DIGITAL CIRCUITS

(Common to ECE and EIE)

Time: 3 hours

Max. Marks: 70

PART – A
(Compulsory Question)

- 1 Answer the following: (10 X 02 = 20 Marks)
- What is meant by linear wave shaping?
 - How can an uncompensated attenuator be modified as a compensated attenuator?
 - List the applications of voltage comparators.
 - State Clamping circuit theorem.
 - What is the main advantage of an emitter-coupled monostable multivibrator over collector-coupled monostable multivibrator?
 - What is meant by loading in a bistable multivibrator?
 - Draw a current sweep circuit.
 - Define the terms phase delay and phase jitter.
 - List the applications of sampling gates.
 - List the disadvantages of ECL.

PART – B

(Answer all five units, 5 X 10 = 50 Marks)

UNIT – I

- 2 (a) A ramp $V_i = \alpha t$ is applied as input to a low-pass RC circuit. Derive the expression for the output voltage. And also draw the typical waveforms.
- (b) A 20 KHz square wave is applied to a RC differentiating circuit, with $R = 4 \text{ K}\Omega$, it produces the output with a tilt of 5%. Calculate the value of the capacitor and lower 3-dB frequency.

OR

- 3 (a) Derive the expression for percentage tilt, 'P' when a square wave is input to a high-pass RC circuit.
- (b) An oscilloscope test probe shown below has a cable capacitance of 50pF. The input impedance of oscilloscope is $1 \text{ M}\Omega$ in parallel with 5pF. Find the value of the capacitor for better performance.

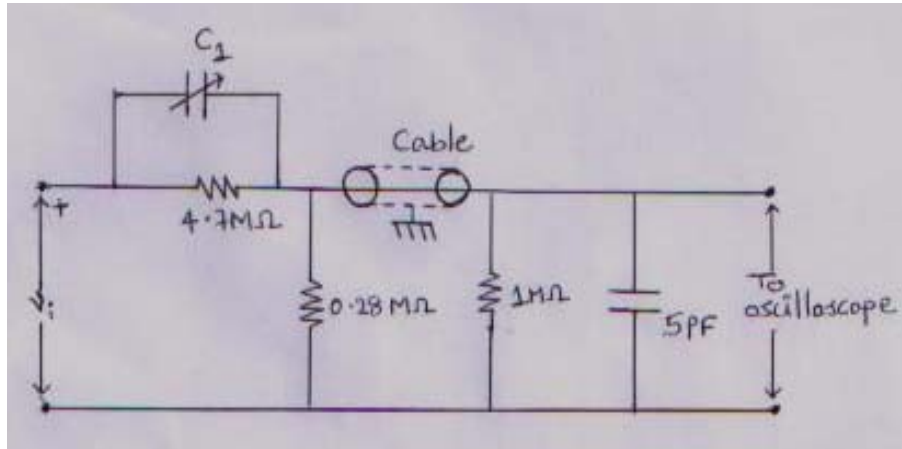

Contd. in page 2

UNIT – II

- 4 (a) For the two-level clipper in Figure below, the input varies linearly from 0 to 150 V. Plot the transfer characteristic and obtain the output voltage. Assume ideal diodes.

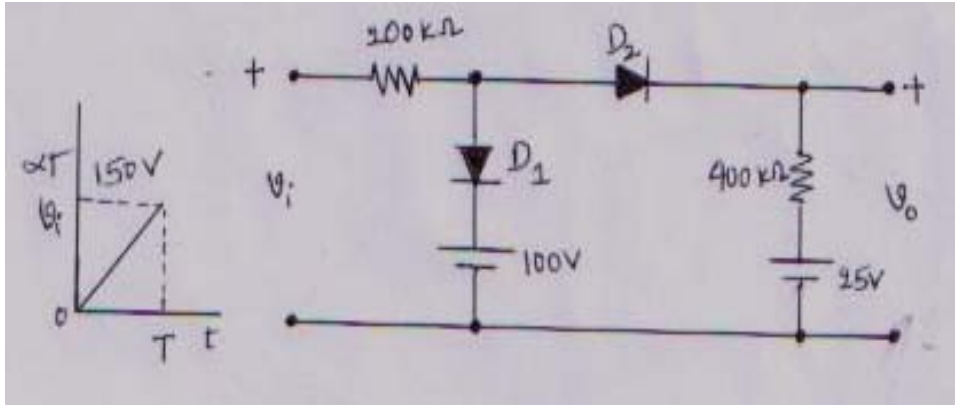

- (b) What is meant by synchronized clamping?

OR

- 5 (a) Explain the effect of diode characteristics on clamping voltage.
 (b) Discuss any two applications of voltage comparators.

UNIT – III

- 6 In a Schmitt trigger circuit shown below, with two 7N4418 n-p-n epitaxial planar silicon transistors, the h_{FE} of the transistors is 70. The circuit is energized from a power supply voltage $V_{CC} = 10$ V. The resistors in the circuit are $R_s = 3.3$ K Ω , $R_{c1} = 2.2$ K Ω , $R_{c2} = 820$ Ω , $R_1 = 1.8$ K Ω , $R_2 = 6.8$ K Ω and $R_e = 4.7$ K Ω . Determine the two voltages associated with upper-tripping point and lower-tripping point.

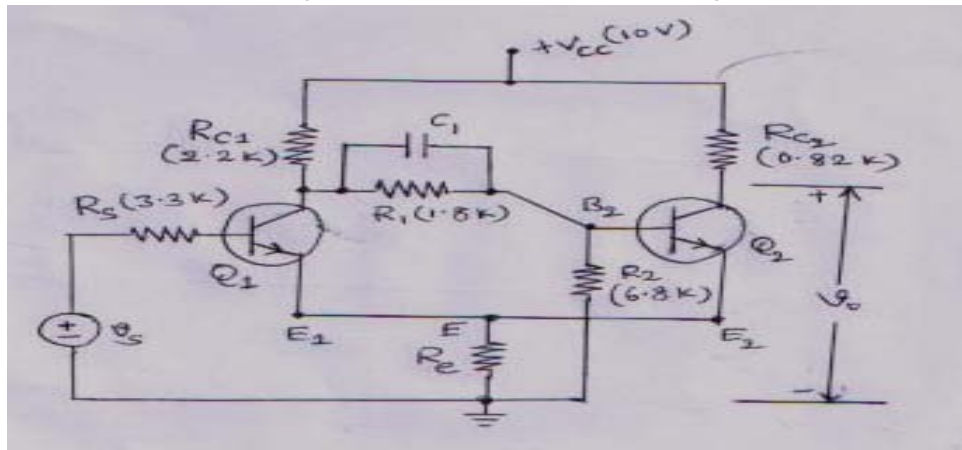

OR

- 7 (a) Draw and explain the operation of collector-coupled astable multivibrator.
 (b) Distinguish between symmetrical triggering and unsymmetrical triggering.

UNIT – IV

- 8 (a) Define the three errors that specify deviation from linearity.
 (b) Explain the basic principle of a bootstrap sweep generator. Draw the circuit and explain its operation.

OR

- 9 (a) Explain the synchronization of a sweep circuit with symmetrical signals.
 (b) Write a brief note on frequency division in a sweep circuit.

UNIT – V

- 10 (a) Draw the circuit of a bidirectional sampling gate and derive the expression for its gain.
 (b) Explain about reduction of pedestal in a gate circuit.

OR

- 11 (a) With a neat sketch explain the working of a DTL NAND gate.
 (b) Compare various logic families.