



c20-c-503

**7620**

**BOARD DIPLOMA EXAMINATION, (C-20)**

**OCTOBER/NOVEMBER—2023**

**DCE – FIFTH SEMESTER EXAMINATION**

**QUANTITY SURVEYING—II**

Time : 3 Hours ]

[ Total Marks : 80

**PART—A**

3×10=30

- Instructions :**
- (1) Answer **all** questions.
  - (2) Each question carries **three** marks.
  - (3) Answers should be brief and straight to the point and shall not exceed five simple sentences.
  - (4) If any data is missing assume suitably.

1. Draw the rough plan of dog-legged staircase. (not to scale)
2. Calculate the length of cranked bar of 10 mm dia, used in one-way slab. As shown in FIG. A.

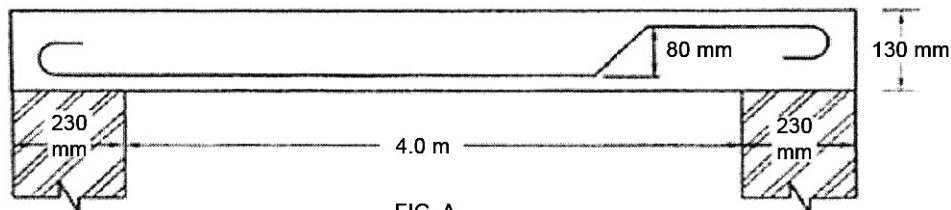

3. Calculate the number of stirrups of 8 mm dia in a RCC simply supported beam of size 230 × 300. Spacing stirrups is 200 mm c/c. Total length of beam is 6.2 m. End covers 25 mm.
4. Prepare the detail estimate, for earthen road of length 50.00 m, top width 7.5 m and bottom width 9.5 m. Height of embankment is 0.60 m from ground. The existing ground level is uniform.

/7620

1

[ Contd...

5. A cement concrete pavement of thickness 150 mm, 5.5 m wide laid over 100 mm thick base course of length 1000 m. Calculate the quantity of cement concrete required for pavement.
6. Find quantity of masonry for parapet wall for an open well with following data :
  - (a) Internal dia of well - 4.00 m
  - (b) Thickness of wall - 300 mm
  - (c) Height of wall - 1.00 m
7. Find quantity of C.C. 1 : 4 : 8 for foundation of Barrel of length 6.5 m as shown in FIG. B.

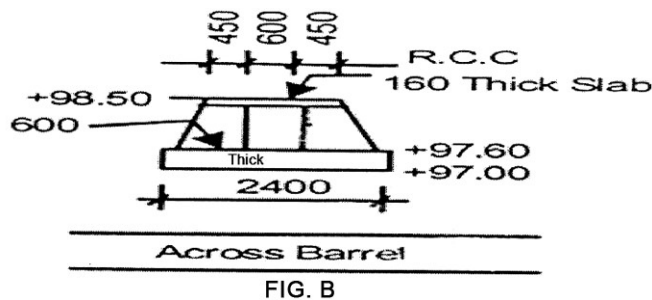

All dimensions are in mm.  
 RL in meters.

8. Define value and cost.
9. State the methods for valuation for a building.
10. The cost of building including cost of land is ₹50,000. The owner expects 10% return. If the expenditure on all outgoings including sinking fund is ₹5,000, then find the gross rent of property per month.

**PART—B**

8×5=40

- Instructions :** (1) Answer **all** questions.  
(2) Each question carries **eight** marks.  
(3) Answers should be comprehensive and criterion for valuation is the content but not the length of the answer.  
(4) If any data is missing assume suitably.

- 11. (a)** Prepare bar bending schedule for a RCC lintel. Reinforcement details are shown in FIG. C. Bottom, top and side covers-20 mm.

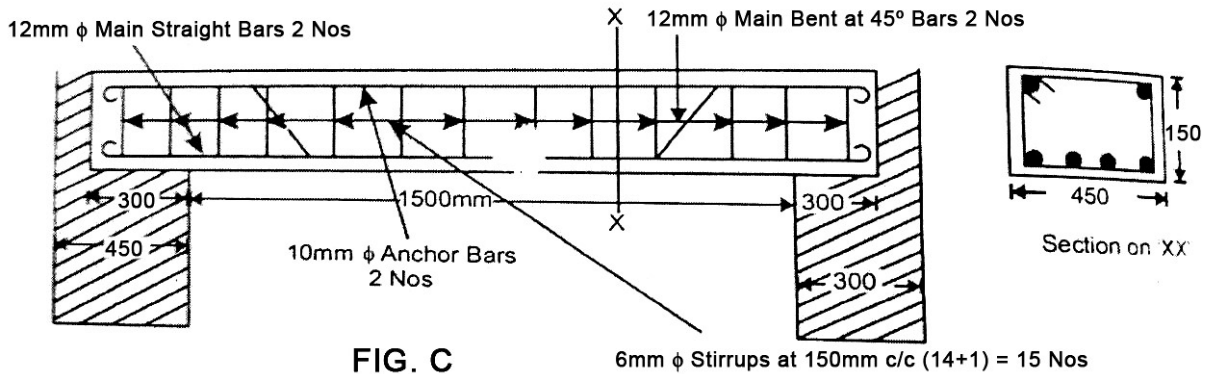

Wt. of bars per meter length 12mm-0.89 kg, 10mm-0.62 kg, 8 mm-0.39 kg, 6mm-0.22 kg.

**(OR)**

- (b)** Prepare bar bending schedule for a RCC one way slab. Reinforcement details are shown in fig.

Size of room-3.5 × 8 m

Bearing on walls-300 mm

Main bars-10 mm dia @ 100 mm c/c along shorter span and alternative bars cranked both sides at distance of 400 mm from support

Over all depth of slab-120 mm

Distribution bars-8 mm @ 200 mm c/c

Covers-bottom and top covers-15 mm, end covers-20 mm

Provide extra bars to hold the cranked bars 8 mm dia 3 no. on each side.

Wt. of bars per meter length 12 mm-0.89 kg, 10 mm-0.62 kg, 8 mm-0.39 kg, 6 mm-0.22 kg.

12. (a) Prepare detailed estimation for W.B.M. road of length 2.00 km. Details are shown in FIG. D for the following works :

- (i) Collection and supply of 40 mm HBG metal for wearing course
- (ii) Collection and supply of 65 mm HBG metal for base course

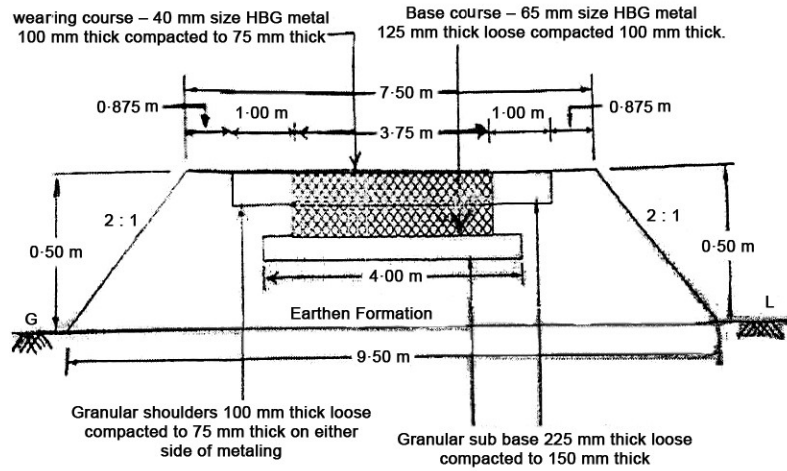

FIG. D

(OR)

(b) Calculate the following quantities for RCC slab culvert as shown in FIG. E :

- (i) Earth excavation for foundation for abutment and return walls
- (ii) R.R. masonry in CM 1 : 3 for abutment and returns up to bottom of deck slab

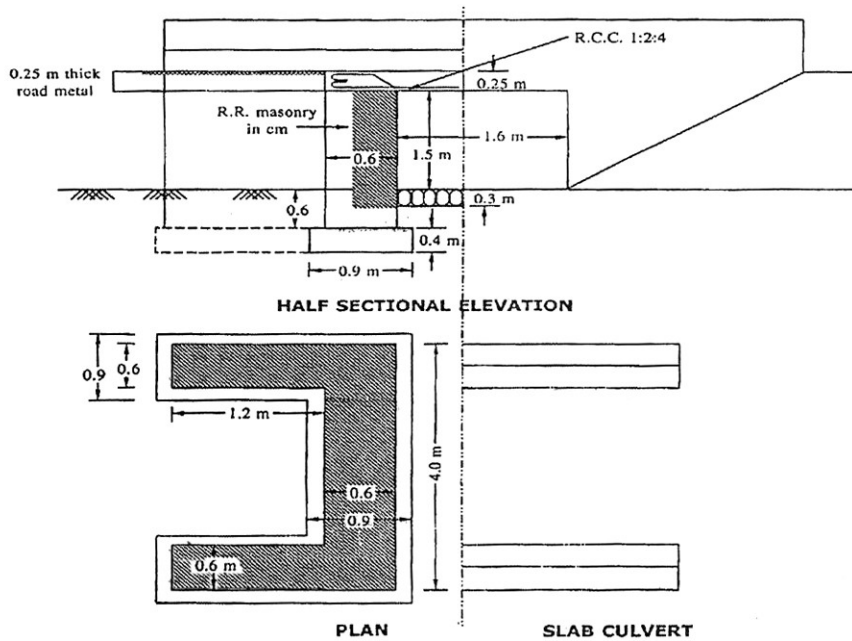

FIG. E

13. (a) Calculate the following quantities for an overhead tank as shown in FIG. F.

- (i) Earthwork excavation for column foundations
- (ii) RCC (1 : 2 : 4) for side walls of 150 mm thick

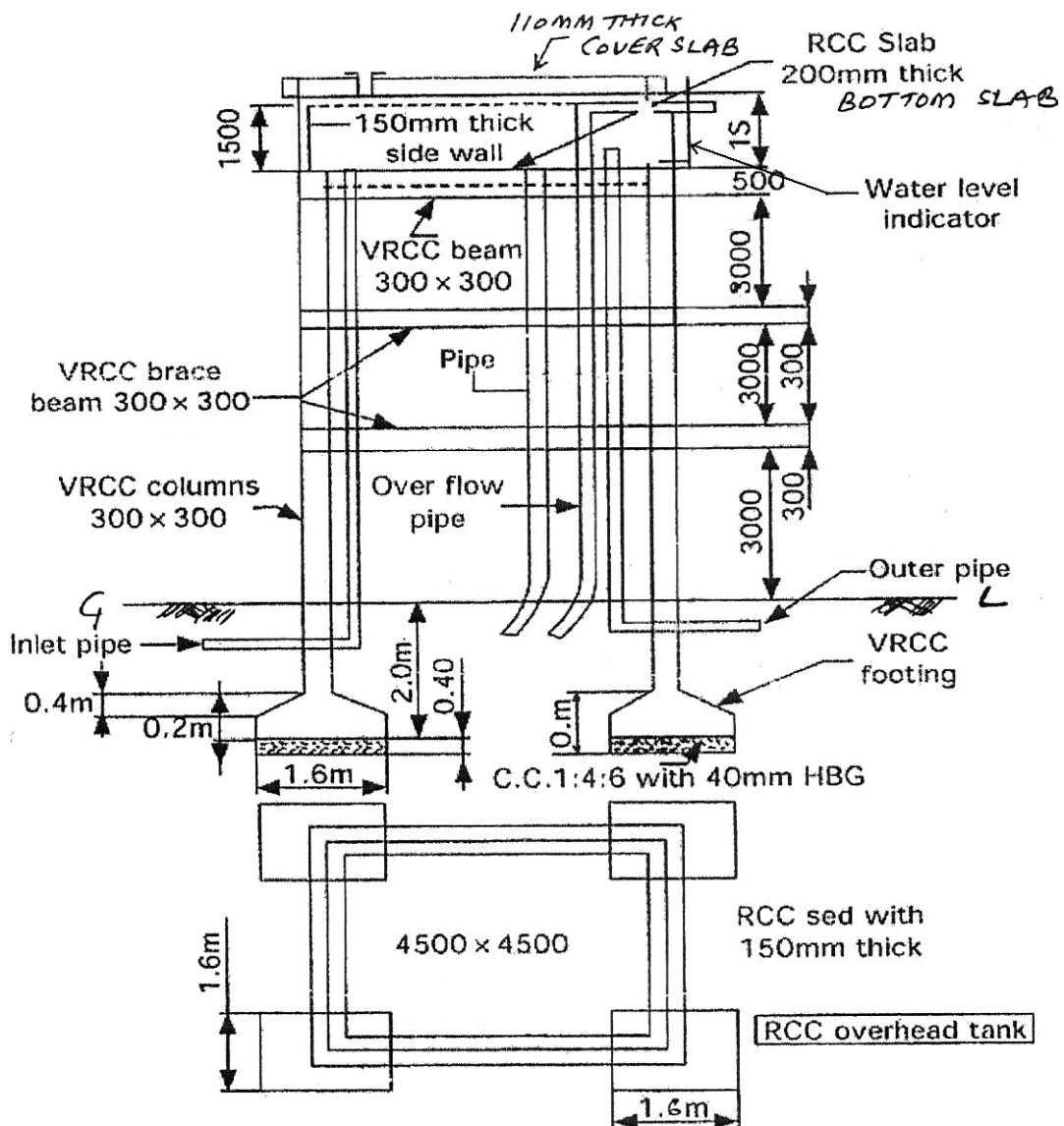

FIG. F

(OR)

(b) Prepare detailed estimate for the following items of work open well shown in FIG. G :

(i) Laterite stone dry packing for well steining for 4th and 3rd mattu

(ii) R.R. masonry in CM 1 : 6 for well steining for 2nd and 1st mattu

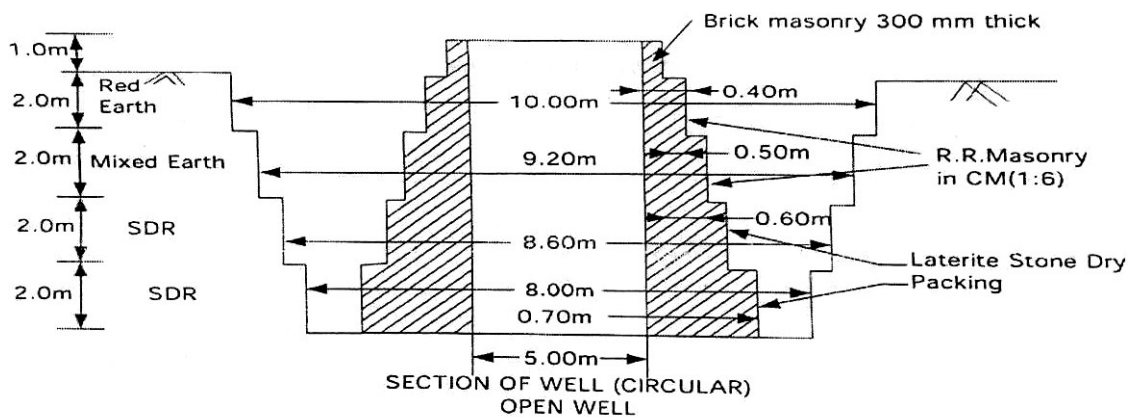

FIG. G

14. (a) A residential building of 200 sq.m. plinth area is situated on plot measuring 400 sq.m. The building let out for a rent of ₹6,000 per month. The cost of land is ₹2,000 per sq.m. The usual outgoings are estimated as 20% of gross rent. Find capitalized value of the property for 10% net yield, assuming usual life of building as 70 years.

(OR)

(b) A residential building constructed 15 years ago is situated on a plot of area 500 sq.m. The plinth area of the building is 300 sq.m. The present cost of the construction of the building is ₹2,50,000. The cost of the land is ₹100 per sq.m. The rate of depreciation for the building is 3.0%. Calculate the value of the property.

15. (a) A building recently constructed costing ₹15,00,000 measuring 100 sq.m. in big city. Prevailing rate of land ₹4,000 per sq.m. Determine the net rent of the property, if the outgoings including sinking fund is ₹35,000 per year. Calculate also gross rent of the property per month. Net return expected by the owner on building is at 6% and on the land is at 4%.

(OR)

(b) Write provisions to be considered for fixation of rent of a building.

**PART—C**

10×1=10

- Instructions :** (1) Answer the following question.  
(2) The question carries **ten** marks.  
(3) Answer should be comprehensive and the criterion for valuation is the content but not the length of the answer.

**16.** Prepare bar bending schedule for RCC square column of size 400 × 400 mm and base 1500 × 1500 mm as shown in FIG. H. Assume suitable covers and use tor steel and neglect hooks for main reinforcement.

