



C20-EE-106

7040

BOARD DIPLOMA EXAMINATION, (C-20)

OCTOBER / NOVEMBER—2023

DEEE – FIRST YEAR EXAMINATION

BASIC ELECTRICAL ENGINEERING

Time : 3 Hours]

[Total Marks : 80

PART—A

3×10=30

- Instructions :** (1) Answer **all** questions.
(2) Each question carries **three** marks.
(3) Answers should be brief and straight to the point and shall not exceed five simple sentences.

1. State Ohm's law.
2. Compare series and parallel circuits in any three aspects.
3. Define electrical energy and mentions its S.I. unit.
4. State Joule's law of electric heating.
5. List six merits of CFL lamps.
6. Define (a) Magnetic Field and (ii) Flux density.
7. State Fleming's left hand rule.
8. State Faraday's laws of electromagnetic induction.
9. State Lenz's law.
10. State Coulomb's laws of electrostatics.

PART—B

8×5=40

- Instructions :** (1) Answer **all** questions.
(2) Each question carries **eight** marks.
(3) Answers should be comprehensive and criterion for valuation is the content but not the length of the answer.

11. (a) Find current when a battery of 60 V is connected between A and B.

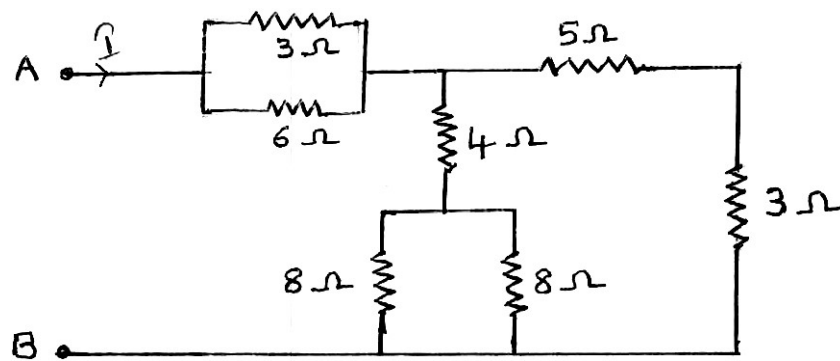

(OR)

- (b) A conductor has a resistance of 5Ω at 40°C . Calculate the resistance at 80°C . Given that temperature co-efficient of resistance at 0°C is $0.0043/^\circ\text{C}$.

12. (a) Two bulbs $60\text{ W}, 200\text{ V}$ and $40\text{ W}, 200\text{ V}$ are connected in series across 200 V DC supply. Calculate power absorbed by each lamp. If they are connected in parallel across 200 V , what is the power absorbed by each?

(OR)

- (b) Calculate the monthly electricity bill for a month of 30 days, for the following loads in a house.

- (i) Four lamps of 100 W each used for 8 hours/ day
- (ii) Two fans of 80 W each used for 10 hours/ day
- (iii) 1000 W iron box used for 1 hour /day

The cost per unit is ₹ 3.00/-

13. (a) Derive an expression for force between two parallel current carrying conductors.

(OR)

- (b) Compare magnetic circuit with electric circuit in any 8 aspects.

14. (a) Derive an expression for total inductance when two coils are connected series aiding.

(OR)

- (b) A coil having 1200 turns produces a flux of 0.025 Wb when a current of 2 A pass through it. Calculate the energy stored in the magnetic field.

15. (a) List any eight (8) applications of capacitors.

(OR)

- (b) Three capacitors are having capacitances of 2 μF , 4 μF and 12 μF . Calculate equivalent capacitance when they are connected in (i) series and (ii) parallel.

PART—C

10×1=10

- Instructions :** (1) Answer the following question.
(2) The question carries **ten** marks.
(3) Answer should be comprehensive and the criterion for valuation is the content but not the length of the answer.

16. What are the values of capacitance if capacitor plates distances are reduced by $\frac{1}{4}$ th of original values. Explain it.

★★★