

Code No: 121AH**JAWAHARLAL NEHRU TECHNOLOGICAL UNIVERSITY HYDERABAD****B.Tech I Year Examinations, May - 2016****ENGINEERING DRAWING****(Common to CSE, MIE, PTE)****Time: 3 hours****Max Marks: 75****Answer any five questions****All questions carry equal marks**

- - -

- 1.a) Draw a rectangular hyperbola whose directrices are 40 mm apart and locate its foci and vertices.
- b) An area of 144 sq.cm on a map represents an area of 36 sq.km on the field. Find the RF of the scale, and draw a diagonal scale to show kilometres, hectametres and decametres and to measure up to 10km. Mark a length of 7km, 5hm and 6dm on the scale. [7+8]

OR

- 2.a) Draw an ellipse of major diameter 130 mm and minor diameter 90 mm.
- b) Construct a vernier scale to read meters, decimeters and long enough to measure up to 6 m, when 1 m is represented by 25 mm. Find R.F. and show a distance of 4.36 m on it. [7+8]
- 3.a) A 90 mm long line PQ, lying in the first quadrant, has its end P in the H.P. and end Q in the V.P. The line is inclined at 45° to the H.P. and 30° to the V.P. Draw its projections.
- b) A hexagonal lamina with a 30 mm long side has one of the sides perpendicular to the V.P. The surface of the lamina is parallel to and 15 mm above the H.P. Draw its projections. [7+8]

OR

- 4.a) A 90 mm long line PQ, is inclined at 45° to the H.P. and 30° to the V.P. The end P is 20 mm above the H.P. and in the V.P. Draw its projections and locate its traces.
- b) A circular plane with a 60 mm diameter has its centre 20 mm above the, H.P., and 30 mm in front of the V.P. The surface of the plane is parallel to the H.P. Draw its projections. [7+8]
- 5.a) A cube with a 45 mm edge is resting on the H.P. with a vertical face inclined at 30° to the V.P. Draw its projections.
- b) A pentagonal prism, having a base with a 30 mm side and a 60 mm long axis, is resting on a face on the H.P. with its axis making 30° with the V.P. It is cut by a horizontal section plane passing through a point 10 mm below the top longer edge. Draw its sectional top view. [7+8]

OR

- 6.a) A cylinder with a 50 mm base diameter and 65 mm long axis has its axis 40 mm above the H.P. and perpendicular to the V.P. Draw its projections when one of the bases is 10 mm in front of the V.P.
- b) A triangular prism, having a base with a 70 mm edge and 60 mm height, stands on its triangular face on the ground with one of its rectangular faces perpendicular to the V.P. It is cut by an A.I.P. such that the true shape of the section is a trapezium with 10 mm and 50 mm parallel sides. Draw its projections and print true shape of section. [7+8]

7. A cone of base diameter 70 mm and height 100 mm rests on the HP on its base and is penetrated by a horizontal cylinder of diameter 45 mm. The axis of cylinder is 9 mm away from the axis of the cone and at a distance 30 mm above the base of the cone. Draw the projections of the solids showing the curve of intersection between the solids. [15]

OR

8. A pentagonal prism of base 30mm side and 60mm height is resting on the base in HP such that one of the rectangular face is parallel to the VP. It is cut by a plane perpendicular to VP and 60 degrees inclined to HP and bisecting the axis of the solid. Draw development of lateral surface of the bottom part of the solid. [15]
9. A cube of 50 mm edge lies with a face on the ground and an edge on the picture plane. All the vertical faces are equally inclined to PP. The SP is 80 mm from PP and 60 mm from GP. The edge of the cube in contact with the picture plane is situated 10 mm to the right of the station point. Draw the perspective view of the cube. [15]

OR

10. Draw the elevation, top view and side view of the object shown in figure. All dimensions are in mm. [15]

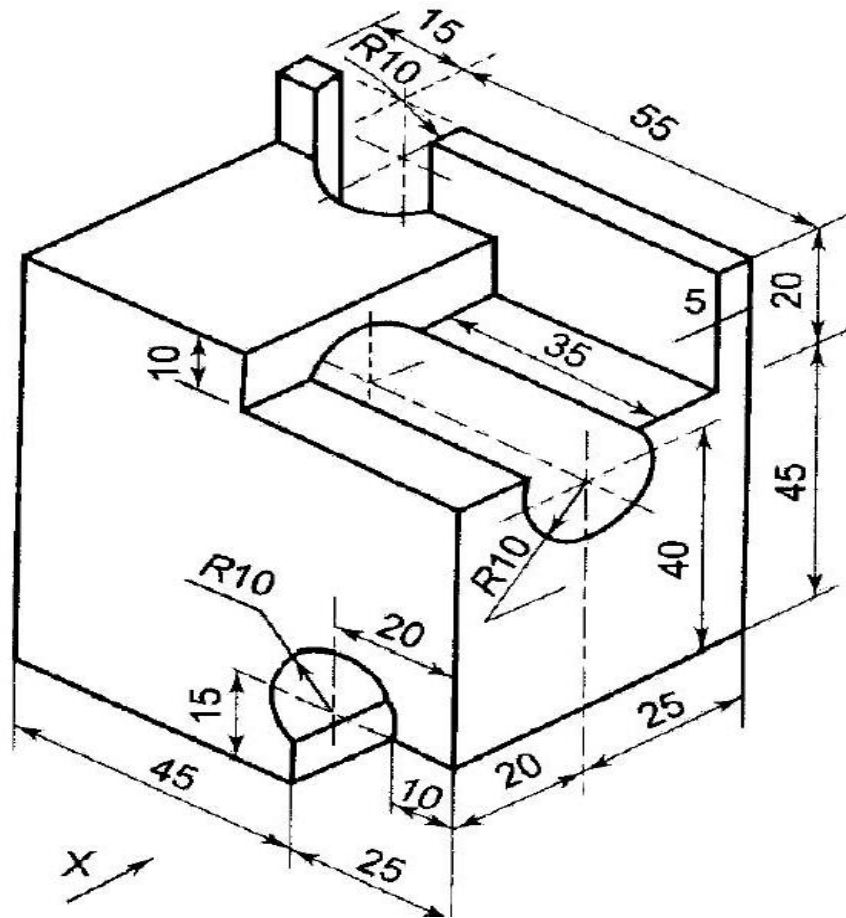

---ooOoo---