

I B. Tech II Semester Regular Examinations, April/May - 2017
ENGINEERING DRAWING
 (Com. to CE, EEE, BIO)

Time: 3 hours

Max. Marks: 70

- Note: 1. Question Paper consists of two parts (**Part-A** and **Part-B**)
 2. Answering the question in **Part-A** is Compulsory
 3. Answer any **FOUR** Questions from **Part-B**
- ~~~~~

PART -A

1. a) Draw an equilateral triangle of 75mm side and inscribe a circle in it. Draw the (7M)
 projections of the figure, when its plane is vertical and inclined at 30° to the VP
 and one of the sides of the triangle is inclined at 45° to the HP.
- b) Draw the Isometric View: (7M)

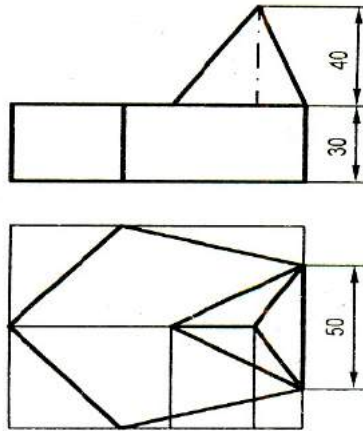

PART -B

2. a) Construct a diagonal scale of RF=1/32 showing yards, feet and inches and to (7M)
 measure up to 4 yards.
- b) Construct an ellipse when the distance of the focus from the directrix is equal to 80 mm (7M)
 and eccentricity is $3/5$.



3. a) A point A is situated in the first quadrant. Its shortest distance from the intersection point of HP and VP and auxiliary plane is 60 mm and it is equidistant from the principal planes. Draw the projections of the point and determine its distance from the principal planes. (7M)
- b) Draw the projections of a 75 mm long straight line in the following positions: (7M)
- Parallel to the both HP & VP and 25mm from each
 - Perpendicular to the HP and 20 mm in front of the VP and its one end 15 mm above the HP
 - Inclined at 45° to the VP, in the HP and its one end in the VP.
4. Draw the projections of a line AB, 90 mm long, its midpoint M being 50 mm above the HP and 40 mm in front of the VP. The end A is 20 mm above the HP and 10 mm in front of the VP. Show the traces and inclinations of the line with the HP and VP. (14M)
5. Draw the projections of a circle of 75 mm diameter having the end A of the diameter AB in the horizontal plane, the end B in the vertical plane, and the surface inclined at 30° to HP and at 60° to the VP. (14M)
6. Draw the projections of a cone, base 75 mm diameter and axis 100 mm long, lying on the ground on one of its generators with the axis parallel to the VP. Assuming the cone to be resting on its base on the ground. Draw its projections. (14M)
7. Draw (i) Front View (ii) Top View (iii) Side View (14M)

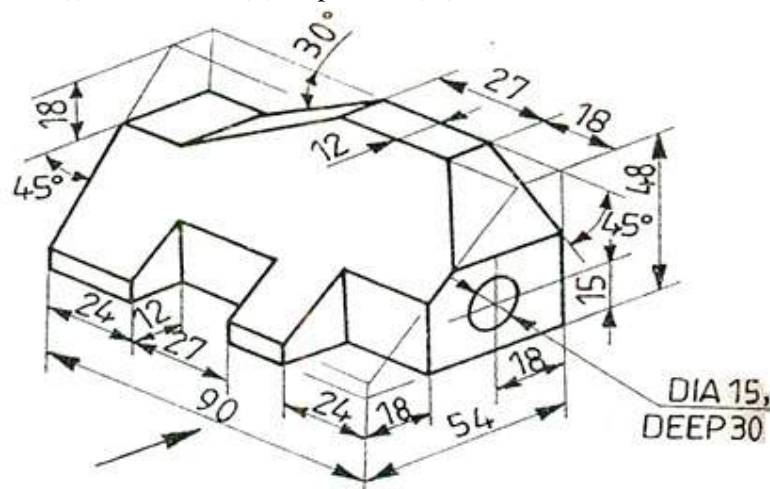

I B. Tech II Semester Regular Examinations, April/May - 2017
ENGINEERING DRAWING
 (Com. to CE, EEE, BIO)

Time: 3 hours

Max. Marks: 70

- Note: 1. Question Paper consists of two parts (**Part-A** and **Part-B**)
 2. Answering the question in **Part-A** is Compulsory
 3. Answer any **FOUR** Questions from **Part-B**

PART - A

1. a) Draw the projections of a regular pentagon of 40 mm side, having its surface inclined at 30° to the HP and a side parallel to the HP and inclined at an angle of 60° to the VP. (7M)
- b) Draw (i) Front View (ii) Top View (iii) Side View (7M)

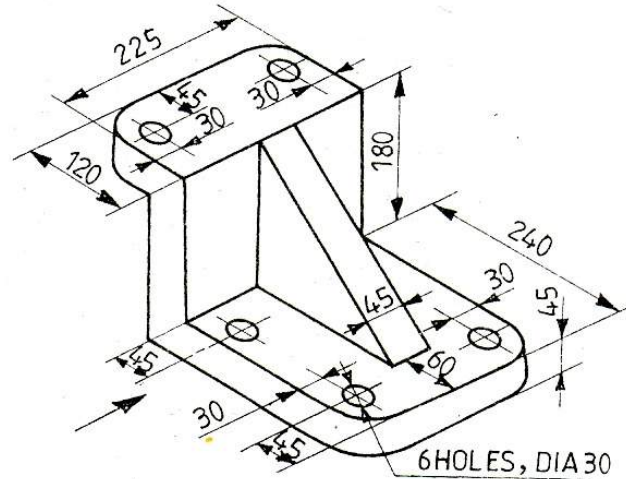

PART - B

2. a) The major axis of an ellipse is 100 mm long and the foci are at a distance of 15 mm from its ends. Find the minor axis. Draw the ellipse by Oblong method. (7M)
- b) Draw a vernier scale of RF=1/25 to read centimetres up to 4 m and on it, show lengths representing 2.39 m and 0.91 m. (7M)
3. a) A point P is 20 mm below HP and lies in the third quadrant. Its shortest distance from xy is 40 mm. Draw its projections. (7M)
- b) The length of the top view of a line parallel to the VP and inclined at 45° to the HP is 5 cm. One end of the line is 1.2 cm above the HP and 2.5 cm in front of the VP. Draw the projections of the line and determine its true length. (7M)



4. The front view of a line makes an angle of 30° with xy . The HT of the line is 45 mm in front of the VP while its VT is 30 mm below the HP. One end of the line is 10 mm above the HP and the other end 100 mm in front of the VP. Draw the projections of the line and determine its true length and its inclinations with the HP and VP. (14M)
5. A thin circular plate of 70 mm diameter is resting on its circumference such that its plane is inclined 60° to the HP and 30° to the VP. Draw the projections of the plate. (14M)
6. Draw the projections of a cylinder 75 mm diameter and 100 mm long, lying on the ground with its axis inclined at 30° to the VP and parallel to the ground. (14M)
7. Draw the Isometric view: (14M)

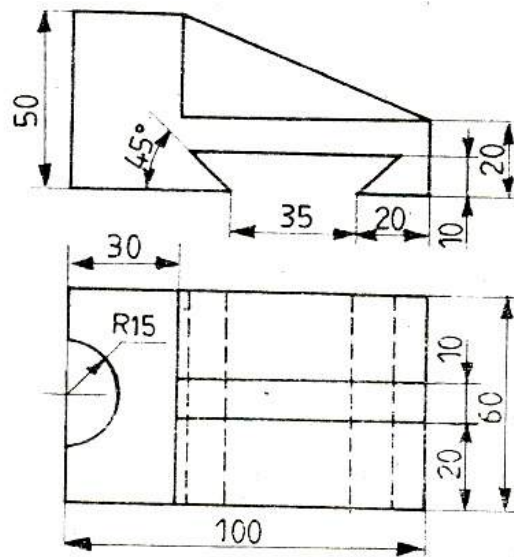

I B. Tech II Semester Regular Examinations, April/May - 2017
ENGINEERING DRAWING
 (Com. to CE, EEE, BIO)

Time: 3 hours

Max. Marks: 70

- Note: 1. Question Paper consists of two parts (**Part-A** and **Part-B**)
 2. Answering the question in **Part-A** is Compulsory
 3. Answer any **FOUR** Questions from **Part-B**

PART -A

1. a) A composite plate of negligible thickness is made up of a rectangle 60 mm × 40 mm, and a semi-circle on its longer side. Draw its projections when the longer side is parallel to the HP and inclined at 45° to the VP, the surface of the plate making 30° angle with the HP. (7M)
- b) Draw the Isometric View (7M)

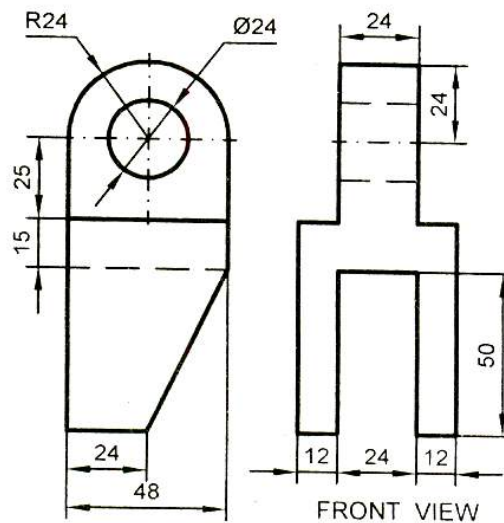

PART -B

2. a) The foci of an ellipse 90 mm apart and the minor axis is 65 mm long. Determine the length of major axis and draw the ellipse by oblong method. Draw a curve parallel to the ellipse and 25 mm away from it. (10M)
- b) Construct a regular hexagon of 40 mm side. (4M)



3. a) A point 30 mm above xy line is the top view of two points P and Q. The front view of P is 45 mm above the HP while that of the point Q is 35 mm below the HP. Draw the projections of the points and state their positions with reference to the principal planes and their quadrants in which they lie. (7M)
- b) A vertical line AB 75 mm long has its end A in the HP and 25 mm in front of the VP. A line AC 100 mm long, it is in the HP and parallel to the VP. Draw the projections of the line joining B and C, and determine its inclinations with the HP. (7M)
4. Two oranges on a tree are respectively 1.8 m and 3 m above the ground, and 1.2 m and 2.1 m from a 0.3 m thick wall, but on the opposite side of it. The distance between the oranges, measure along the ground and parallel to the wall is 2.7 m. Determine the real distance between the oranges. (14M)
5. A 60° set square of 125 mm longest side is so kept that the longest side is in the HP making an angle of 30° with the VP and the set square itself inclined at 45° to the HP. Draw the projections of the set square. (14M)
6. Draw the projections of a pentagonal prism, base 25 mm side and axis 50 mm long, resting on one of its rectangular faces on the ground, with the axis inclined at 45° to the VP. (14M)
7. Draw (i) Front View (ii) Top View (iii) Side View (14M)

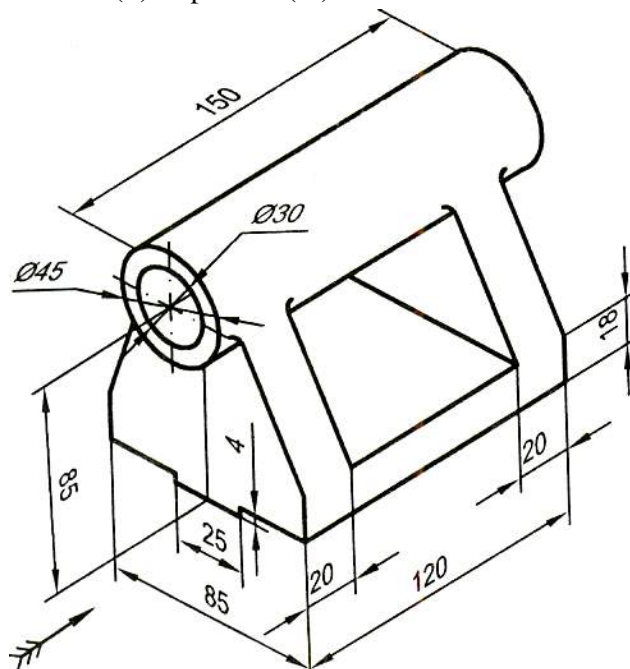

I B. Tech II Semester Regular Examinations, April/May - 2017
ENGINEERING DRAWING
 (Com. to CE, EEE, BIO)

Time: 3 hours

Max. Marks: 70

- Note: 1. Question Paper consists of two parts (**Part-A** and **Part-B**)
 2. Answering the question in **Part-A** is Compulsory
 3. Answer any **FOUR** Questions from **Part-B**

PART -A

1. a) A semi-circular plate of 80 mm diameter has its straight edge in the VP and inclined at 45° to the HP. The surface of the plate makes an angle of 30° with the VP. Draw its projections. (7M)
 b) Draw (i) Front View (ii) Top View (iii) Side View (7M)

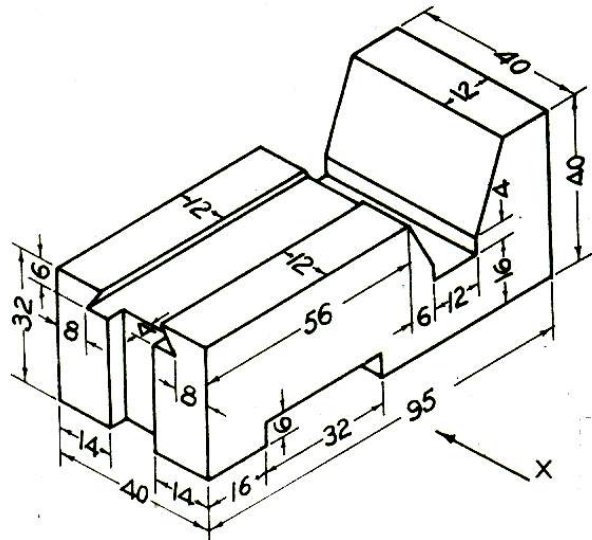

PART -B

2. a) Draw a vernier scale of R.F. = 5 to read $1/5$ cm and $1/25$ cm and to measure upto 5 cm. Mark on a scale distances of 2.12 cm and 4.29 cm. (7M)
 b) The major axis of an ellipse is 150 mm long and the minor axis 100 mm long. Find the foci and draw the ellipse by arcs of circles method. Draw a tangent to the ellipse at a point on it 25 mm above the major axis. (7M)
3. a) A 100 mm long line is parallel to and 40 mm above the HP. Its two ends are 25mm and 50 mm in front of the VP respectively. Draw its projections and find its inclinations with the VP. (7M)
 b) A point P is 15 mm above the HP and 20 mm in front of the VP. Another point Q is 25 mm behind the VP and 40 mm below the HP. Draw the projections of P and Q keeping the distance between their projectors equal to 90 mm. Draw straight lines joining their top views and their front views. (7M)



4. The projectors drawn from the HT and VT of a straight line AB are 80 mm apart (14M) while those drawn from its ends are 50 mm apart. The HT is 35 mm in front of the VP, the VT is 55 mm above the HP and the end A is 10 mm above the HP. Draw the projections of AB and determine its length and inclinations with the reference planes.
5. Draw a regular hexagon of 40 mm side, with its two sides vertical. Draw a circle of 40 mm diameter in its centre. The figure represents a hexagonal plate with a hole in it and having its surface parallel to the VP. Draw its projections when the surface is vertical and inclined at 30° to the VP. Assume the thickness of the plate to be equal to that of a line. (14M)
6. A hexagonal pyramid, base 25 mm side and axis 50 mm long, has an edge of its base on the ground. Its axis is inclined at 30° to the ground and parallel to the VP. Draw its projections. (14M)
7. Draw the Isometric view: (14M)

