

Total No. of Questions—8]

[Total No. of Printed Pages—4+2

Seat No.	
-------------	--

[4957]-1002

**S.E. (Civil) (I Sem.) EXAMINATION, 2016**  
**STRENGTH OF MATERIAL**  
**(2012 PATTERN)**

**Time : Two Hours**

**Maximum Marks : 50**

- N.B. :-** (i) Neat diagrams must be drawn wherever necessary.  
(ii) Figures to the right indicate full marks.  
(iii) Use of electronic pocket calculator is allowed.  
(iv) Assume suitable data, if necessary.  
(v) Answer Q. No. 1 or Q. No. 2, Q. No. 3 or Q. No. 4,  
Q. No. 5 or Q. No. 6, Q. No. 7 or Q. No. 8.

1. (a) A steel bar  $35\text{mm} \times 35\text{mm}$  in section and  $100\text{mm}$  in length is acted upon by a tensile load of  $180\text{ kN}$  along its longitudinal axis and  $400\text{ kN}$  and  $300\text{ kN}$  along the axes of the lateral surface. Determine :
- (i) Change in the dimension of the bar.  
(ii) Change in volume.

Take  $E = 205\text{ GPa}$ . Fig. 1 :

[6]

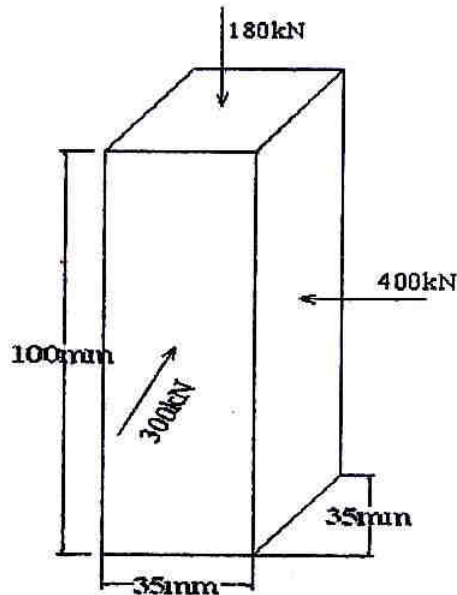

Fig. 1

P.T.O.

- (b) A simply beams 8 m span carrying UDL of 10 kN/m and permissible stress in the material of beam is  $30 \text{ N/mm}^2$ . Design the section of beam if depth to width ratio is 2 [6]

Or

2. (a) Derive relation between modulus of elasticity  $E$  and bulk modulus  $K$ . [6]
- (b) Maximum bending moment of simply supported beam is 10 kNm. The cross section of the beam is as shown in Fig. 2. Find the maximum bending stress in tension and compression. [6]

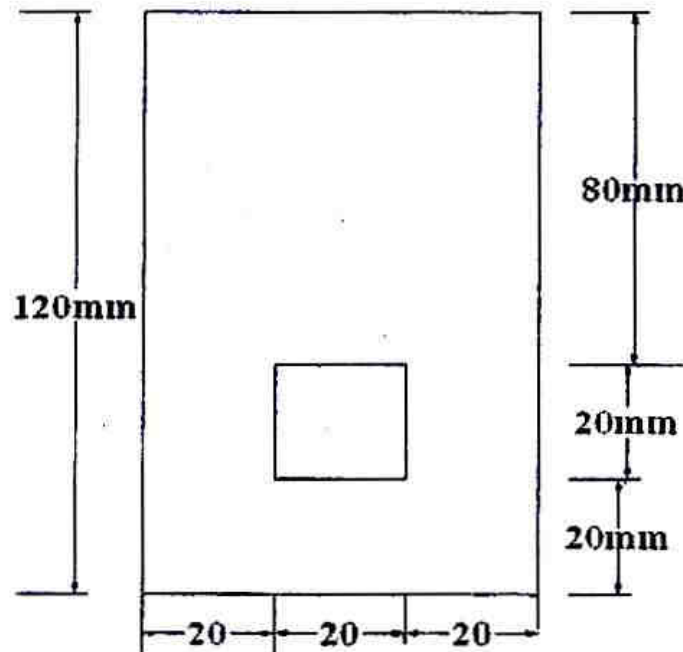

Fig. 2

3. (a) A hollow circular shaft of 200 mm external diameter, thickness of metal 20 mm is rotating at 180 r.p.m. The angle of twist on 3 m length was found to be 0.7 degree. Calculate the power transmitted and maximum shear stress induced in the material. Take  $G = 80 \times 10^3 \text{ MPa}$ . [6]

- (b) A block  $120 \text{ mm} \times 80 \text{ mm}$  thick is subjected to uniformly distributed stress fields as shown in Fig. 3. Compute the normal stress and shear stress development along the plane BD. Also finding out the maximum shear stress and corresponding plane. [6]

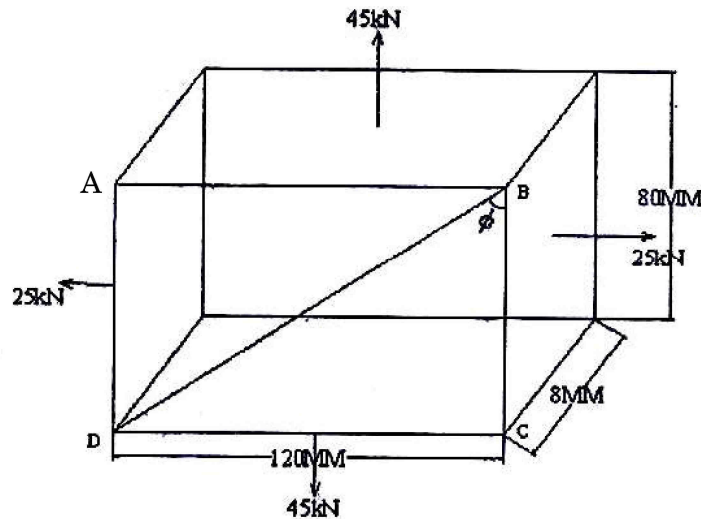

Fig. 3

Or

4. (a) A solid vertical prismatic steel bar of equilateral triangular section of side 20 mm is firmly fixed at the top. A rigid collar is attached at lower end at a distance of 600 mm from top. Calculate the strain energy stored in each of the following cases. [6]
- When a pull of 10 kN is applied gradually
  - When a force of 8 kN is suddenly applied
  - When a weight of 4 kN falls through 120 mm before it strikes the collar. Take  $E = 200 \text{ GPa}$ .

- (b) A solid steel shaft of 60 mm diameter is to be replaced by a hollow steel shaft of the same material with internal diameter equal to half of the external diameter. Find the diameter of the hollow shaft and saving in material, if the maximum allowable shear stress is same for both shafts. [6]

5. (a) An overhang beam ABC is loaded as shown in Fig. 5.1. Draw the shear force diagrams and bending moment diagrams and find the point of flexure, if any : [7]

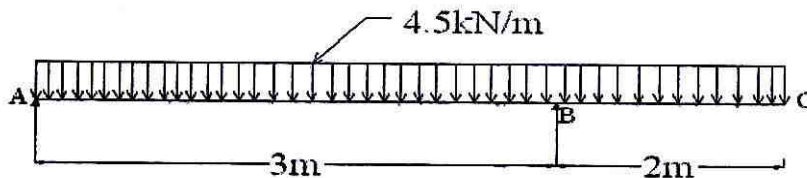

Fig. 5.1

- (b) A simply supported beam 8m long carries three point loads at 50 kN, 100 kN, 150 kN at 2 m, 5 m and 7 m from left roller support. The self weight of the beam is 25 kN/m. The rigid end support is hinged. Draw S.F.D. and B.M.D. for the beam. (Fig. 5.2) [6]

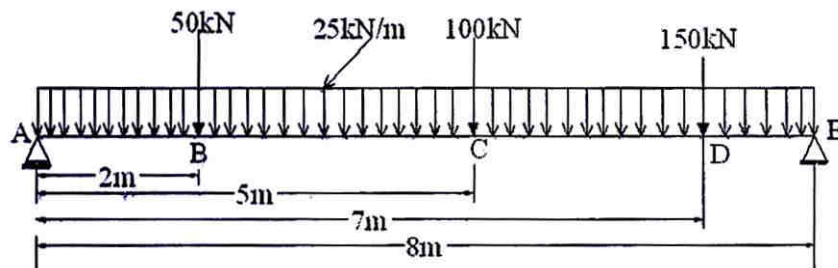

Fig. 5.2

Or

6. (a) A beam ABCD, 8m long is overhanging by 2m and carries load as shown in Fig. 6.1. Draw S.F.D. and B.M.D. for the beam and locate the point of contraflexure. [6]

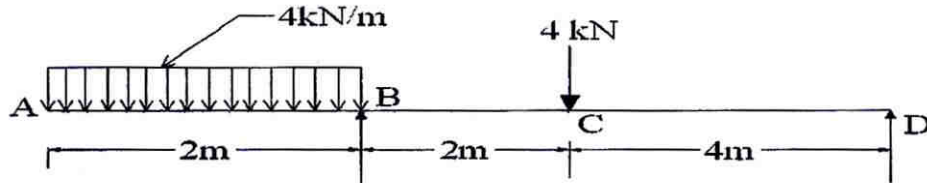

Fig. 6.1

- (b) The Diagrams as shown in Fig. 7 is the shear force diagram for a beam which rest on two supports. Construct the bending moment diagram and loading diagram. (Fig. 6.2) [7]

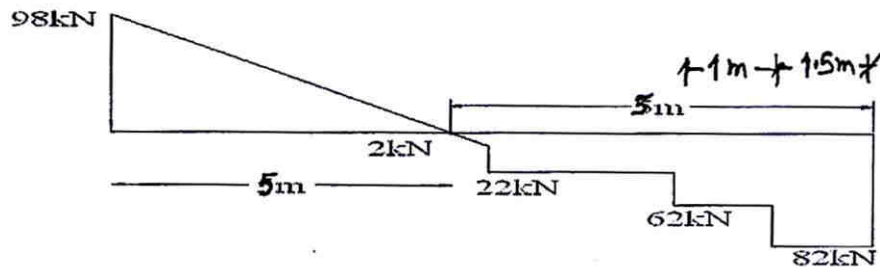

Fig. 6.2

7. (a) An alloy tube 25mm internal diameter and 40mm external diameter when subjected to axial tensile force of 60 kN undergoes an extension of 3.84mm over its 3m length. What is its safe axial load resisting capacity as a column, when one end is fixed and the other end hinged ? Factor of safety may be taken as 4. [6]
- (b) State assumption made in Eulers theory and its limitation. [7]

Or

8. (a) Determine the crippling load for a hollow rectangular cast iron column of outer dimension  $100\text{ mm} \times 80\text{ mm}$ , thickness of metal  $10\text{ mm}$ , actual height of column  $6\text{ m}$  with both ends fixed. Take  $E = 120\text{ GPa}$  [6]
- (b) A hollow circular steel column having external diameter  $200\text{ mm}$  and internal diameter  $150\text{ mm}$  carries a vertical load of  $80\text{ kN}$  acting with an eccentricity of  $50\text{ mm}$ . Calculate maximum and minimum stress intensities in the section. (Fig. 8) [7]

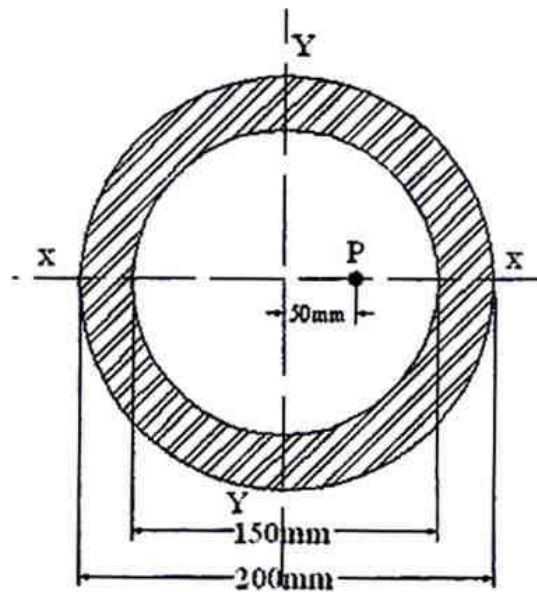

Fig. 8