

**STRUCTURAL ANALYSIS - II**  
**(2012 Course) (Semester - I)**

[Time : 2½ Hours]

[Max. Marks : 70]

Instructions to the candidates:

- 1) Answer questions Q1 or Q2, Q3 or Q4, Q5 or Q6, Q7 or Q8.
- 2) Figures to the right side indicate full marks.
- 3) If necessary, assume suitable data & indicate clearly.
- 4) Use of electronic pocket calculator is allowed.

**Q1) a)** Analyse the beam shown in fig. by slope deflection method. **[10]**

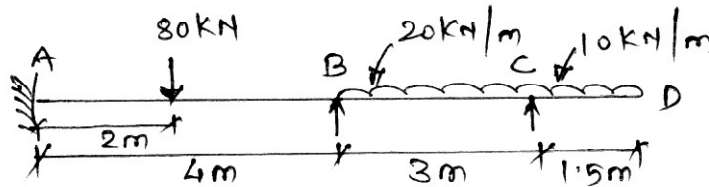

b) Analyse the continuous beam shown in fig. by flexibility method. **[10]**

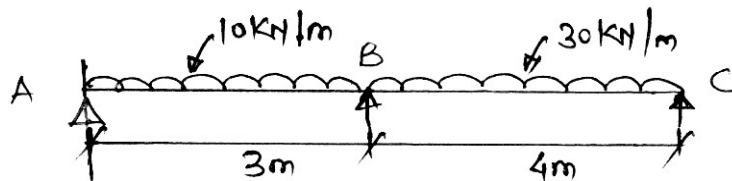

OR

**Q2) a)** Analyse the frame as shown in fig. using moment distribution method. **[10]**

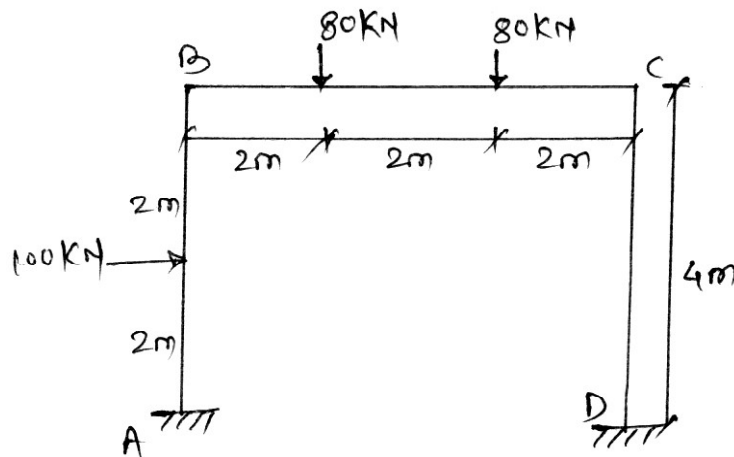

P.T.O.

- b) Analyse the portal frame shown in fig. by slope deflection method. Draw BMD. [10]

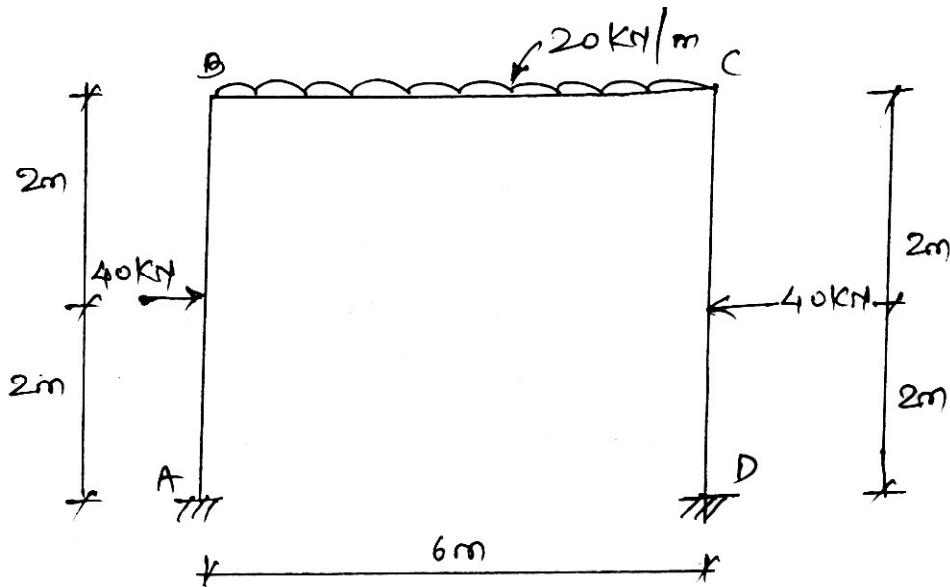

- Q3) Analyse the beam shown by shiffness matrix method. Draw BMD & elastic curve. Take  $E = \text{Const}$ . [16]

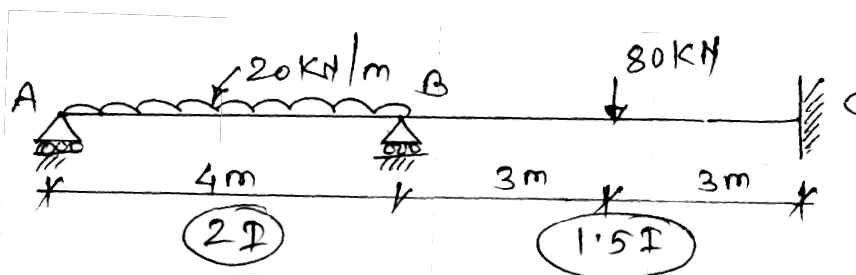

OR

- Q4) Analyse the frame by shiffness matrix method & sketch BMD. Take  $EI = \text{Const}$ . [16]

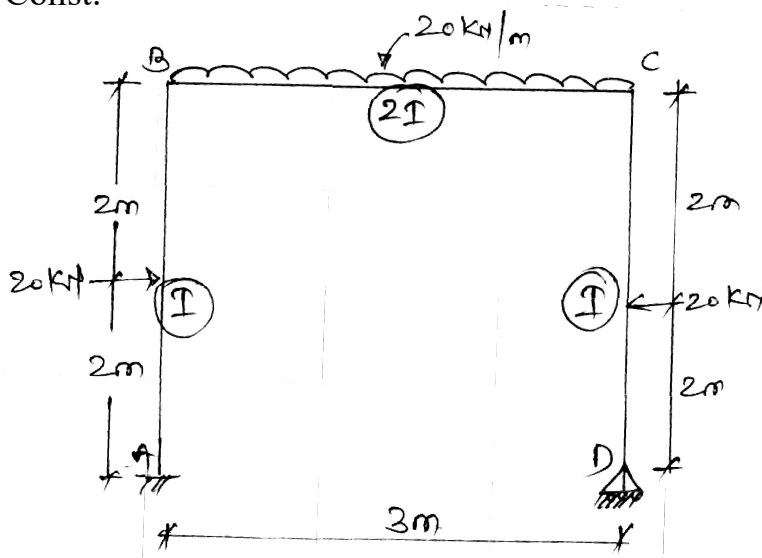

**Q5) a)** Analyse the frame by using Cantilever method & Draw BMD. [10]

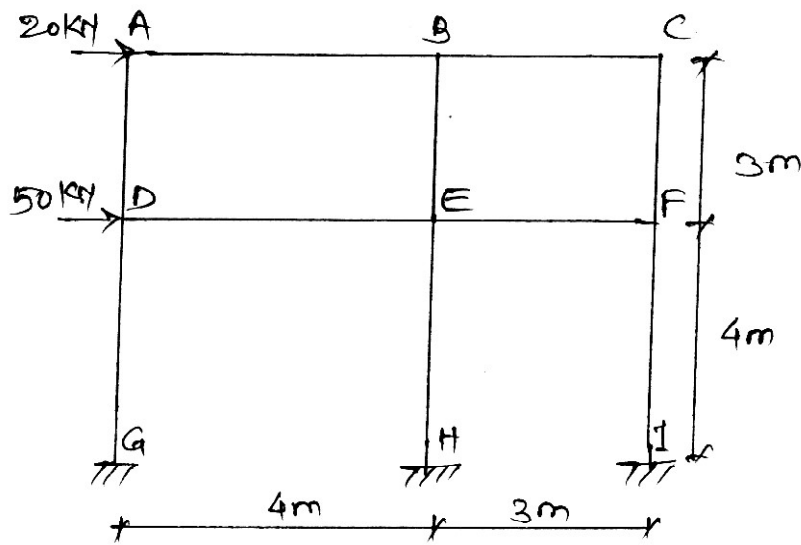

b) Using finite difference method. Determine deflection under load. Use 5 nodes. [8]

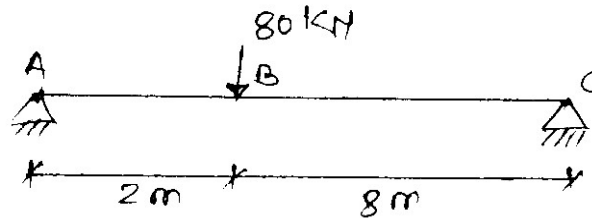

OR

**Q6) a)** Analyse the frame by portal method & Draw BMD. [10]

b) Using finite element method find maximum displacement for Cantilevers. Take 4 nodes. [8]

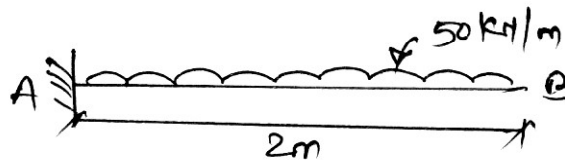

**Q7) a)** Explain principal of minimum potential energy. [8]

b) Determine shape functions for the constant strain triangle (CST) using polynomial function. [8]

(OR)

**Q8) a)** Explain convergence criteria for FEM. [8]

b) Explain plain stress and plain strain problem. [8]

