

Total No. of Questions :6]

SEAT No. :

P83

APR. -16/TE/Insem. - 15

[Total No. of Pages :2

T.E.(Electrical)

CONTROL SYSTEM-I

(2012 Course) (Semester - II) (303147)

Time : 1Hour]

[Max. Marks :30

Instructions to the candidates:

- 1) Answer Q1 or Q2, Q3 or Q4, Q5 or Q6.
- 2) Neat diagrams must be drawn whenever necessary.
- 3) Figures to the right indicate full marks.
- 4) Your answers will be valued as a whole.

Q1) a) Classify open loop and close loop system with their advantages and limitations. [4]

b) Find transfer function for following figure. [6]

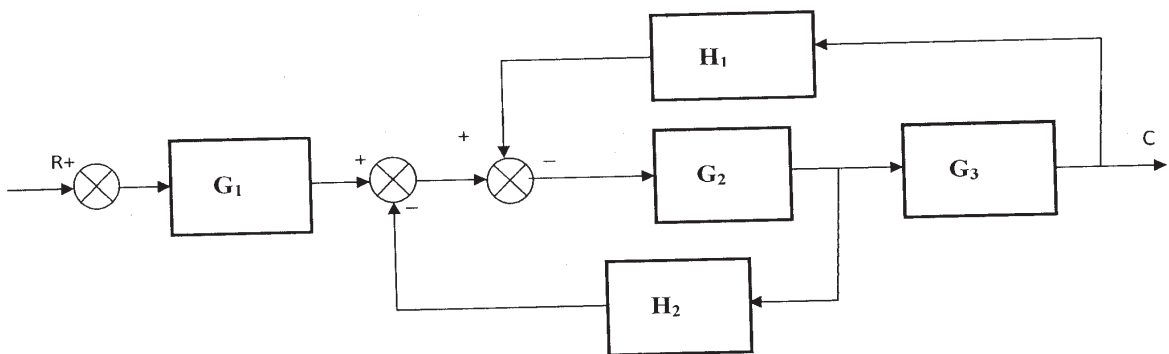

OR

Q2) a) State and explain Mason's gain formula. [4]

b) Find transfer function using Mason's gain formula for following system. [6]

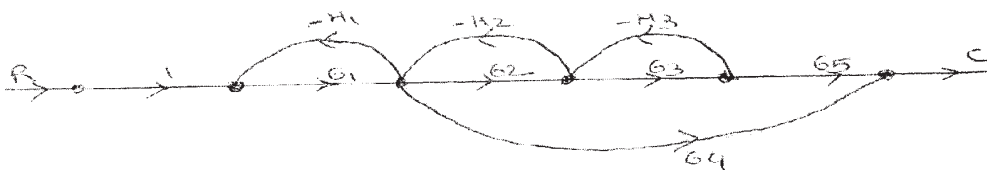

P.T.O.

- Q3) a)** Derive transfer function for separately excited DC shunt motor. [7]  
**b)** Explain force voltage analogy. [3]

OR

- Q4) a)** Derive transfer function for following electrical system [6]

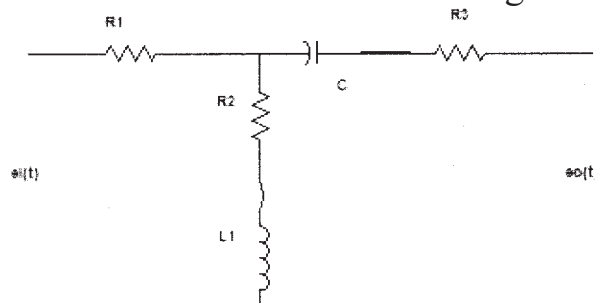

- b)** Explain gear train and how they are modelled. [4]  
**Q5) a)** Draw time response of standard second order system and explain time response specifications. [5]

- b)** For a unity feedback systems having open loop transfer function as

$$G(s) = \frac{24(s+2)}{s(s^2+7s+12)} \text{ Determine.} \quad [5]$$

- i) Type of system  
 ii) Error constants  $K_p$ ,  $K_v$  and  $K_a$   
 iii) Steady state error for step input.

OR

- Q6) a)** A unity feedback system is characterized by an open loop transfer function

$$G(s) = \frac{k}{s(s+10)} \text{ Determine the gain } K \text{ so that the system will have damping ratio of } 0.7. \text{ For this value of } K \text{ determine settling time, peak overshoot and time to peak overshoot.} \quad [6]$$

- b)** What are different standard test signals draw them and find their laplace transform. [4]

