



Seat No.	
----------	--

**T.E. (Electrical) (Semester – I) Examination, 2014
ADVANCED MICROCONTROLLER AND ITS APPLICATIONS
(2012 Course)**

Time : 3 Hours

Max. Marks : 70

- Instructions :** 1) Answer **all** questions.
2) Neat diagrams must be drawn **wherever** necessary.
3) Figures to the **right** side indicate **full** marks.
4) **Use** of calculator is **allowed**.
5) Assume suitable data if **necessary**.

1. a) Compare Harvard and Van Neumann architecture. 7
b) Explain any three addressing modes of PIC 18 with one example each. 6
c) Write an assembly program using the timer1 interrupt to create a square wave of 3 KHz on pin RB7. Assume XTAL = 10 MHz. 7

OR

2. a) Explain the status register of PIC 18 microcontroller. 6
b) Write an assembly language program to add the constant AAH to the contents of file reg 0 x 36 and store the result in file reg 0 x 40. 7
c) Explain different I/O ports and associated SFRs of PIC 18F458. 7
3. a) A LED is connected to port pin RB1 and a switch (SW) is connected to RB0 as shown in figure. Write a program which will continuously monitor status of port pin RB0 and switch on LED when the switch is closed. 8

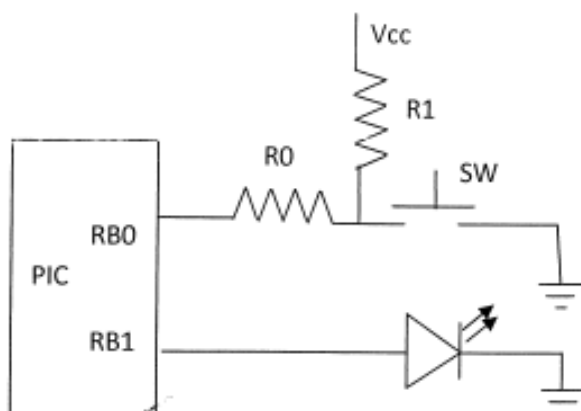

- b) Explain the functions of pins associated with LCD (16 x 2) and draw a flowchart for outputting data on LCD. 8

OR

P.T.O.



- 4. a) Write a program to transfer a letter 'A' serially and continuously at a baud rate of 9600. Assume crystal frequency of 10 MHz. 8
- b) Write a short note on SPI protocol. 8
- 5. a) Explain compare mode of operation of PIC 18 and also explain SFR CCP1 CON register in detail. 8
- b) Using compare mode, write the assembly language program to toggle the LED every 10 pulses. Use Timer 1 as counter. 8
- OR
- 6. a) Create a 2 KHz PWM frequency with 25% duty cycle on the CCP1 pin. Assume XTAL = 10 MHz. 8
- b) Explain PIC 18 connection to the stepper motor and write the code to rotate continuously in anticlockwise direction. 8
- 7. a) Explain features of on-board ADC and the following SFR's in detail ADCON1 ADCON 0. 9
- b) Show interfacing of LM35 with PIC 18F458. Write a program to measure and display temperature. 9
- OR
- 8. a) Explain how current is measured using PIC 18F458. Write a program to measure current and display result in PORT D. 9
- b) Explain with a neat diagram, interfacing of DAC with PIC microcontroller and write a program for sawtooth waveform generation using DAC. 9

B/II/14/