

Total No. of Questions—8]

[Total No. of Printed Pages—3

Seat No.	
-------------	--

[4956]-105

F.E. (First Semester) EXAMINATION, 2016

BASIC ELECTRONICS ENGINEERING

(2012 PATTERN)

Time : Two Hours

Maximum Marks : 50

- N.B. :—**
- (i) Figures to the right indicate full marks.
 - (ii) Neat diagrams must be drawn wherever necessary.
 - (iii) Use of electronic pocket calculator is allowed.
 - (iv) Assume suitable data, if necessary.

- 1.**
- (a) Draw and Explain full wave rectifier with capacitor filter. [6]
 - (b) Explain CE amplifier with the help of DC loadline. [6]

Or

- 2.**
- (a) Explain with V-I characteristics the working of Zener diode as a voltage regulator. [6]
 - (b) Define α and β in case of transistor. Derive the relationship between them.
If $\alpha = 0.98$, Calculate value of β . [6]
- 3.**
- (a) Draw a neat diagram of 3-input inverting summing amplifier and obtain expression for its o/p voltage. [6]

P.T.O.

- (b) Compare synchronous and asynchronous counter. [4]
 (c) State Demorgan's theorem. [2]

Or

4. (a) For the given circuit. Find V_o . [6]

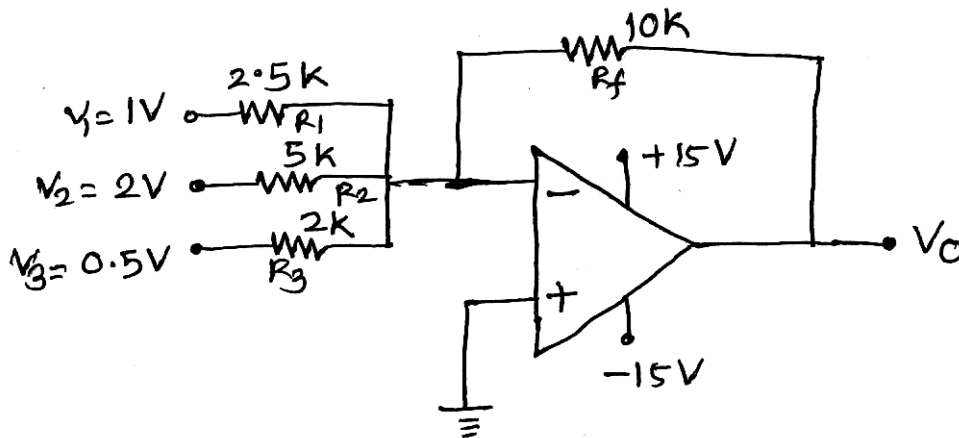

- (b) Compare microprocessor and microcontroller. [4]
 (c) Explain how Ex-OR gate can be used as an inverter. [2]
5. (a) Draw a constructional diagram of SCR and Explain its working with the help of two transistor analogy. [6]
 (b) With a neat diagram explain construction and working of LVDT. Give its advantages and applications. [7]

Or

6. (a) Compare : [6]
 (i) SCR and TRIAC
 (ii) DIAC and TRIAC.

- (b) Draw and explain electronic weighting machine. [5]
- (c) Define :
- (i) Active Transducer
 - (ii) Passive Transducer. [2]
7. (a) Define AM. Derive expression for AM. Write expression for modulation index. Draw waveforms of AM. [7]
- (b) Write short note on :
- (i) Coaxial Cable
 - (ii) Fiber Optic Cable. [6]
8. (a) Draw and Explain block diagram of GSM system. [6]
- (b) With respect to FM explain
- (i) Frequency deviation
 - (ii) Modulation index
 - (iii) Deviation ratio
 - (iv) Frequency spectrum of FM. [7]