

Total No. of Questions—8]

[Total No. of Printed Pages—4+1

Seat No.	
-------------	--

[4957]-1043

**S.E. (E & TC/Electronics) (First Semester) EXAMINATION, 2016**  
**NETWORK THEORY**  
**(2012 PATTERN)**

**Time : Two Hours**

**Maximum Marks : 50**

- N.B. :-** (i) Neat diagrams must be drawn wherever necessary.  
(ii) Figures to the right indicate full marks.  
(iii) Use calculator is allowed.  
(iv) Assume suitable data, if necessary.

1. (a) By using mesh analysis find  $V_x$ , in the circuit shown below : [6]

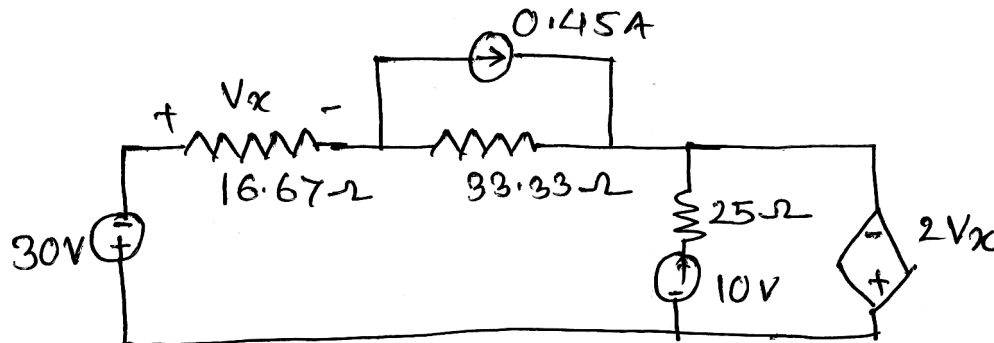

- (b) Explain the following terms with examples : [6]
- (i) Tree
  - (ii) Oriented Graph
  - (iii) Incident matrix.

P.T.O.

Or

2. (a) Write the node voltage equation and determine the current in each branch for the network. [6]

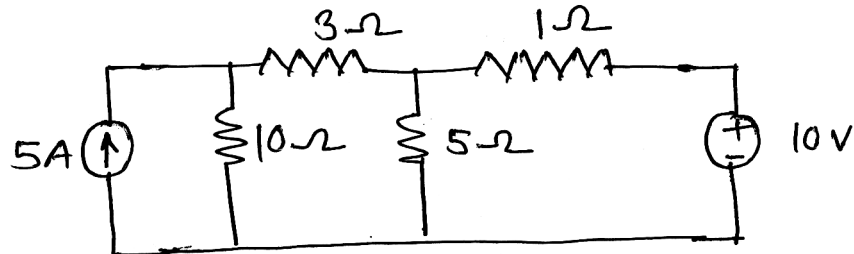

- (b) For the circuit shown below write : [6]
- (i) Tieset
  - (ii) Branch voltage equation.

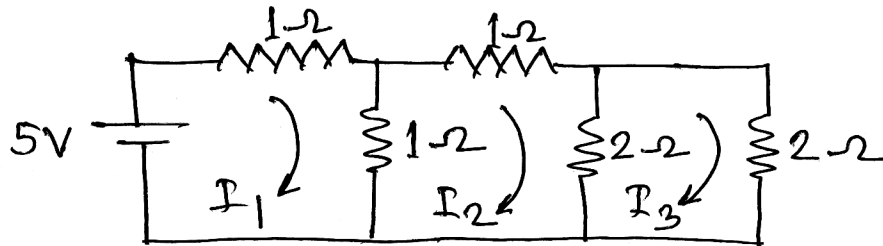

3. (a) Derive the expression for voltage across the capacitor of the circuit shown below. [6]

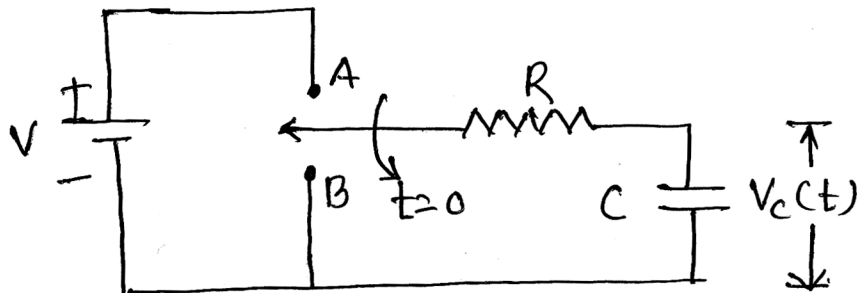

- (b) What is meant by quality factor and explain the significance of it. Obtain the expression of resonant frequency of the circuit shown below. [6]

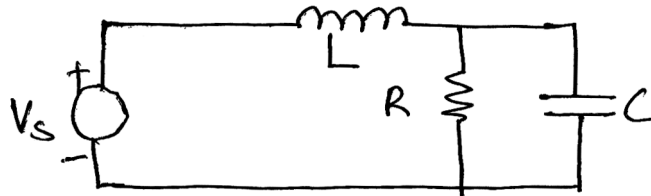

Or

4. (a) A series RC circuit consisting R and C, initially switch is open, at  $t = 0$  it is closed. Find the expression for  $V_C(t)$  and  $i_C(t)$ . [6]

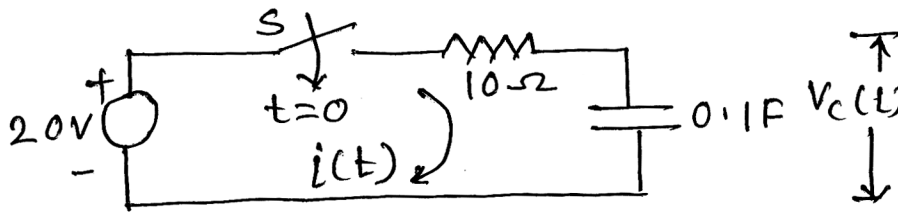

- (b) Obtain the value of 'L' for which the circuit is resonant at 5000 rad/sec. [6]

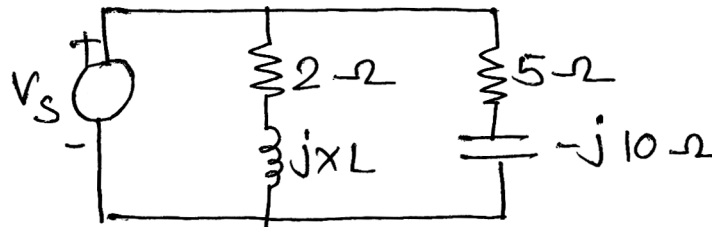

5. (a) Design a T and  $\pi$  section of a high pass filter having a characteristics impedance of  $600 \Omega$  and cut off frequency of 10 KHz. Also find characteristics impedance and phase constant at 25 KHz. [7]
- (b) Design symmetrical attenuator with attenuation of 20 dB and design impedance of  $600 \Omega$ . [6]

Or

6. (a) For symmetrical 'T' network derive the expression for ' $Z_0$ ' and propagation constant in terms of circuit components. [6]
- (b) Explain the m-derived filter. Design a LPF T and  $\Pi$  section having a cutoff frequency of 2 KHz to operate with a terminated load impedance of  $500 \Omega$ . [7]
7. (a) Find the open circuit parameter for the network. [7]

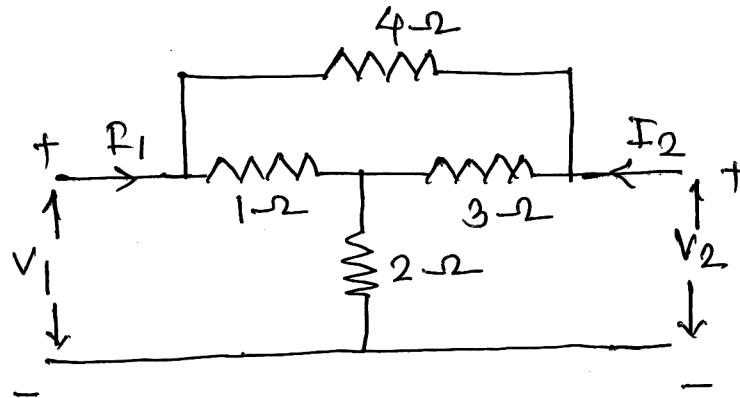

(b) Find the network function : [6]

$$\frac{V_1}{I_1}, \frac{V_2}{V_1} \text{ \& \ } \frac{V_2}{I_1} \text{ for.}$$

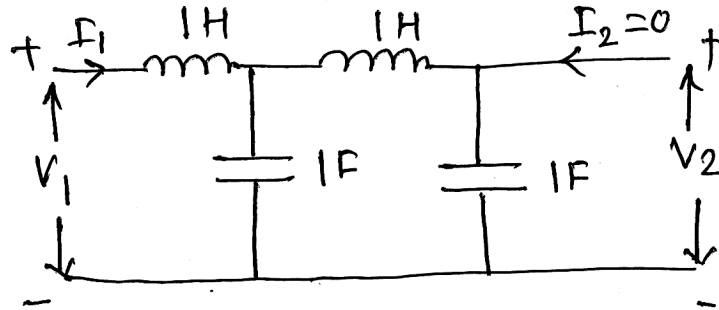

Or

8. (a) Current  $I_1$  and  $I_2$  entering at port 1 and 2 respectively of a two part network are given by : [6]

$$I_1 = 0.5 V_1 - 0.2 V_2$$

$$I_2 = -0.2 V_1 + V_2$$

Find 'Y' and 'Z' parameters.

(b) What is mean by poles and zeros ? Explain the role of poles and zeros to network stability. Find the poles and zeros of the network given below. [7]

